

FS13D120PB & FS13D240PB SERIES 13 AMP PUMP DOWN FLOAT SWITCHES

The FS13D120PB and FS13D240PB Series Pump Switch is used to turn a pump on and off in environments with temperatures up to 140° F. This product can be used for a variety of applications, including but not limited to: septic tanks, sump pits, pump chambers, and any other empty tank applications. Available in 120VAC piggyback plug, and 240VAC piggyback plug.

The pump switches are mechanically operated using switching contacts and are activated by the ball inside the float housing. Available models include: FS13 Series with wide angle switching differentials. For use as empty tank (normally open) configuration with multiple types of float attachments for mounting and various cable lengths.

NOTE: Check to make sure the correct pump switch is being used for the application:

Normally Open (Pump Down) - Contacts are open while hanging down and will close on a rising liquid level. Typically used for empty tank applications.

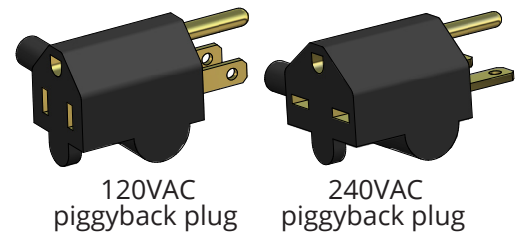

(1) Polypropylene Housing - Designed for temperatures up to 140° F, resistant to harsh chemicals, and withstands high impact. The ridge-less housing design creates optimum operation of the pump float switch and prevents materials from adhering to the housing.

(2) Cable Type - SJ00W (UL/CSA), 16 gauge, 2-conductor, flexible, and water/oil resistant. Available in 120VAC piggyback plug, and 240VAC piggyback plug.

(3) Internal Wiring - Solder dipped wiring with an epoxy filled chamber for moisture seal technology and protection from water intrusion (solder dipped wiring on bare lead models only).

(4) Ball - Located inside the float housing and used to actuate the switching contacts.

(5) Switching Contacts - Activated by the ball inside the float housing causing the contacts to open or close.

(6) Actuator Arm - As the float tilts above/below horizontal, the ball inside the housing will activate or deactivate the actuator arm causing the contacts to turn on/off.

(7) Switching Differential - wide angle (90°) switching differential.

(8) Innovative Mechanical Design - Using patent pending mechanically activated contacts eliminates the hazardous mercury for an environmentally safe product.

(9) Omni-Directional (not shown) - Not sensitive to either rotation or turbulence. The float switch will operate at the designed angle regardless of the direction of the tilt.

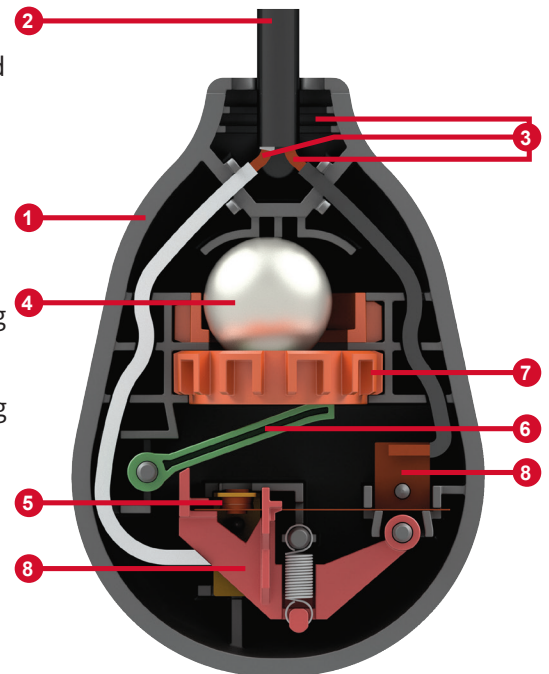

BOSHART
INDUSTRIES

25 Whaley Avenue, PO Box 310, Milverton, ON CANADA N0K 1M0
Tel: 800-561-3164

boshart.com ♦ blog.boshart.com

FS13D120PB & FS13D240PB SERIES 13 AMP PUMP DOWN FLOAT SWITCHES

SPECIFICATION:

- Primary Voltage: 120VAC or 240VAC, 60 Hz (voltage depends on model/part number)
- Amperage: 13 Amps, 120VAC 0.5HP or 240VAC 1.5HP
- Float Housing Material: Polypropylene
- Float Housing Size: 3.0 inches (diameter) x 4.35 inches (length)
- Cable Type: SJ00W (UL/CSA), 16 gauge, 2-conductor, flexible, and water/oil resistant
- Connection Types: Piggyback Plug (120VAC or 240VAC)
- Operating Temperature: 0 - 140° F
- Switching Differential: 90° total (wide angle)
- Switch Configuration: Single Pole, Single Throw (Pump Down only)
- Mounting Method(float attachment): Pipe Clamp, Stainless Steel
- Certifications: CSA (US and Canada)

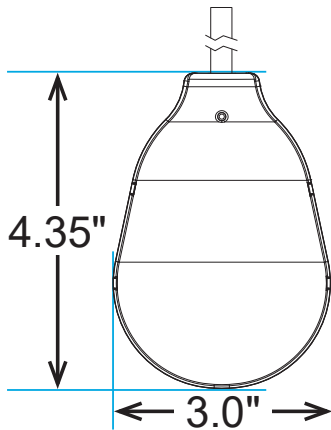

Tether Length (inches)	3.5"	4"	6"	8"	10"	12"	16"	20"	24"
Pumping Range (inches)									
Wide Angle	7"	8"	9.5"	11.5"	13"	16"	18"	22"	26"

CAUTION: USE AS GUIDE ONLY, ACTUAL RANGES MAY VARY
(Reference Only - Testing Must Be Performed for Actual Ranges)

Pump Switches - minimum recommended tether of 3.5"

EMPTY TANK

(normally open example)

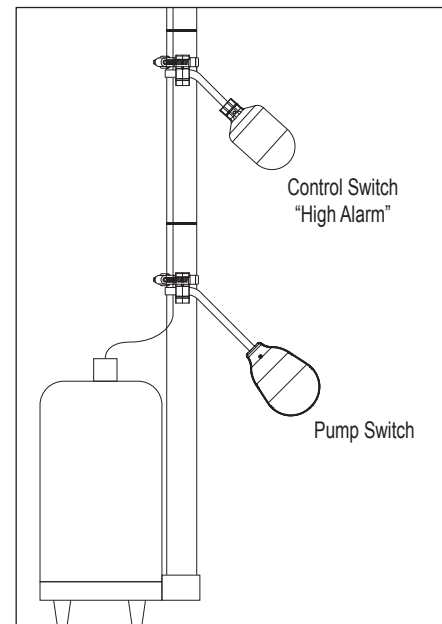

Multiple float switches with pipe clamps are used for a variety of applications to empty a tank or use as high level alarms.

Normally Open (empty):

Control Switch / Top Float = High Alarm

Pump Switch / Bottom Float = Start/Stop Pump

Part No.	Model No.	Cable Length feet
Wide angle; 13 Amps, 120VAC 0.5HP		
FS13D120PB-10	RS13WDPS1WP10	10'
FS13D120PB-15	RS13WDPS1WP15	15'
FS13D120PB-20	RS13WDPS1WP20	20'
FS13D120PB-30	RS13WDPS1WP30	30'
FS13D120PB-50	RS13WDPS1WP50	50'

Part No.	Model No.	Cable Length feet
Wide angle; 13 Amps, 240VAC 1.5HP		
FS13D240PB-10	RS13WDPS2WP10	10'
FS13D240PB-15	RS13WDPS2WP15	15'
FS13D240PB-20	RS13WDPS2WP20	20'
FS13D240PB-30	RS13WDPS2WP30	30'
FS13D240PB-50	RS13WDPS2WP50	50'

For more information on installation, adjustment, repair & operation, visit Boshart Knowledge Base at SUPPORT.BOSHART.COM



BOSHART

INDUSTRIES

25 Whaley Avenue, PO Box 310, Milverton, ON CANADA N0K 1M0
Tel: 800-561-3164

boshart.com ♦ blog.boshart.com